



Course Advanced Manufacturing
Section: Aerospace Engineering



James Rumsey
Technical Institute

Draw a Blueprint

What You Will Do

Learn about basic Orthographic drawings and create a blueprint of an object with dimensions.

1. Read about engineering drawings create your first blueprint with dimensions.
2. Choose an object with simple lines such as a rectangular block of wood or Legos that is easy for you to measure and draw the different sides.
3. Select which sides you want to be the front, right, and top.
4. Create an Orthographic projection of the object that shows 3 sides.
5. Use the ruler to measure the dimensions of your object.
6. Draw the front, top, and right side of the object and add dimensions.

Materials You Will Need

- Pencil
- Paper (graph paper if you have it)
- Eraser
- Ruler
- Small to medium size object

Blueprint

Artists draw objects for others to look at and enjoy. Engineers draw objects so that they can be accurately constructed by others. While there are many different types of drawing methods, this lesson will cover orthographic projection and how to include dimensions.

Important Terms

- **Orthographic projection** - A method of drawing a 3-dimensional object in 2 dimensions.
- **Planar drawings** - Drawings that simplify complex 3D forms into flat, angular planes.
- **Extension lines** - Solid lines that extend from the edges of an object and help define the specific area to which the dimension applies.
- **Dimension lines** - Lines used to show the size or location of features in an engineering drawing.
- **Scale** - A ratio that represents the proportion of the drawing to the actual size of an object. For example, the drawing is 1/3 scale or 3 times smaller than the actual size of the object.

Study Examples

Look at the example provided in Figure 1. In the top right-hand corner, you will see an orthographic drawing of a block that shows a 3-dimensional view with labels for sides.

The other 3 drawings show just the front, top, and right side. The front of the object is usually at the center of the drawing with the top stationed above it and on the right side to it's right.

If there were a need to include a bottom or left drawing, then those would be placed respectively below and to the left.

Figure 2 shows the drawings with extension lines and dimensions added.

After reviewing the drawings, do you believe that you would be able to construct this block based on the information included or do you believe something is missing? If so, what would you include?

Planar and Orthographic Drawing

Measure the sides of your object and write the dimensions down. Which side do you want to be the front or top?

Do your best to make an orthographic drawing of your object. Since this is your first blueprint do not worry about scale. Use your ruler to help create straight edges of your drawing.

Draw the front of the object, then top, and finally the right side as in the examples in figure 1.

Label Measurements

Add extension lines like those in Figure 2 to all the sides you think are necessary to convey to the person making the part. Try not to duplicate dimensions you have already added.

Add dimension lines. Leave a space in the center of the dimension lines for your dimensions.

Add the dimensions.

Look at your blueprint. Do you believe that someone else can build that object using your blueprint?

Practice

Blueprints and drawings are used throughout the aerospace industry. Aircraft manufacturers, mechanics, engineers, and parts manufacturers utilize different drawings to design, repair, and make improvements on aircraft and spacecraft.

Students in the Aerospace Engineering class make drawings of their prototypes during the research and design phases. These serve as the base for CAD (Computer Aided Design) programs.

For practice, choose more complicated objects to draw and/or design part of a remote control aircraft or drone.

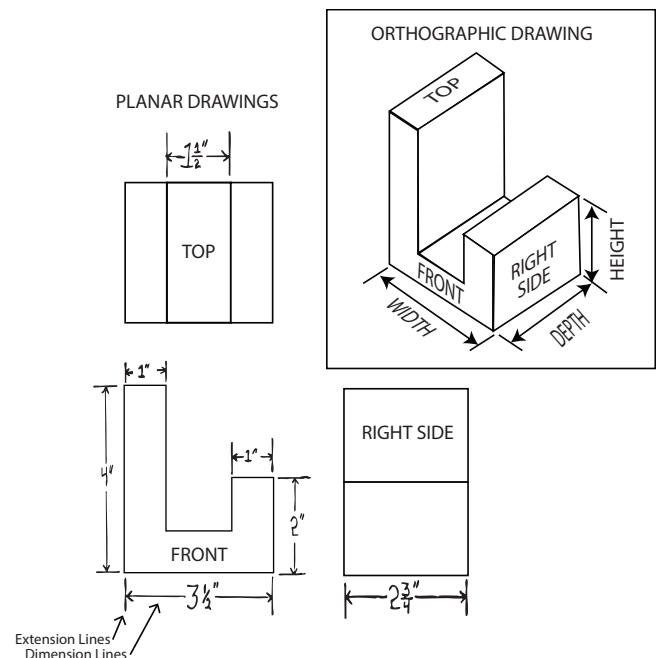

Figure 1